

# Panasonic CONNECT

AW-UE150W [White Model]

AW-UE150K [Black Model]

4K Integrated Camera

AW-RP150

Remote Camera Controller

## Panasonic's 4K 60p/50p\*<sup>1</sup> 12G-SDI Supported PTZ Camera the Industry's First\*<sup>2</sup>



AW-UE150K

SRT ALLIANCE  
SECURE RELIABLE TRANSPORT



For indoor use

4K 60p/50p\*<sup>1</sup> output supported for superior image quality

75.1° field of view for wide-angle shooting

Optical 20x zoom



AW-UE150W



AW-RP150

Large touch panel for  
easy usability

New joystick for  
flexible operability

\*1: Actual output format is UHD (3840 x 2160) 59.94p/50p. \*2: Internal investigation, Oct. 2018.

# AW-UE150

## 4K 60p/50p\*<sup>1</sup> Output, High-Magnification Zoom and Wide-Angle Shooting for Flexible Video Production



**AW-UE150W**

4K Integrated Camera  
[White Model]



**AW-UE150K**

4K Integrated Camera  
[Black Model]



The next-generation PTZ camera supports high-quality video production in stadium, lecture halls, churches and other venues. Smooth and high-quality 4K 60p/50p\*<sup>1</sup>, high-magnification zoom and a wide shooting angle expand the range of the PTZ camera's applications. The camera is equipped with a variety of interfaces and supports simultaneous 4K/HD operation which allows for versatility in current and future production systems.

• Power supply not included. An AC adaptor or PoE++ HUB is required.

### ► High-Quality 4K 60p/50p\*<sup>1</sup> Shooting

3840 x 2160 4K output and 59.94p/50p\*<sup>1</sup> shooting achieve extremely smooth video, even in live sports and other environments containing rapid movement.

#### ■ Output format

<b>4K</b>	2160/59.94p, 2160/50p, 2160/29.97p* <sup>2</sup> , 2160/25p* <sup>2</sup> , 2160/24p* <sup>2</sup> , 2160/23.98p* <sup>2</sup>
<b>HD</b>	1080/59.94p, 1080/50p, 1080/29.97p* <sup>2</sup> , 1080/29.97PsF, 1080/25p* <sup>2</sup> , 1080/25PsF, 1080/23.98p* <sup>3</sup> , 1080/24p* <sup>2</sup> , 1080/23.98p* <sup>2</sup> , 1080/23.98PsF, 1080/59.94i, 1080/50i
	720/59.94p, 720/50p

### ► 1.0-type MOS Sensor Mounted

The large 1.0-type MOS sensor enables high sensitivity shooting with low noise. The sensor boasts a light-capturing area that is approximately four times larger than that of the 1/2.3-type sensor to guarantee a wide dynamic range.

### ► Optical 20x Zoom / Industry's First\* 75.1° Horizontal Wide-Angle Shooting

Adding "i zoom" to our optical 20x zoom, maintains high resolution while enabling ultra-high resolution 32x zoom in HD mode and 24x zoom in 4K mode. This enables distant subjects to be captured clearly. Furthermore, 75.1° horizontal wide-angle shooting enables capture of the entire area, even when installation space is limited.

\* Internal investigation, Nov. 2018.

#### ■ Optical 20x Zoom Image Quality



\* Images are simulated.

#### ■ Horizontal 75.1° Shooting Range

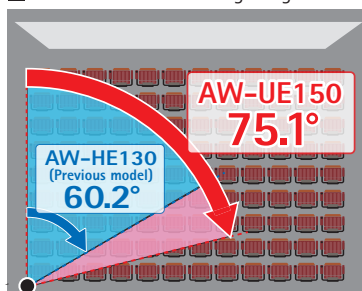

Camera Position



### ► HDR (HLG) Support\*<sup>4</sup>

The camera supports HDR (High Dynamic Range) to prevent blown-out highlights and blocked-up shadows and enable picture quality close to that of the naked eye. Conforms to BT.2020.



HDR Mode OFF



HDR Mode ON

\* Images are simulated.



## ► Optical Image Stabilizer (OIS) Loaded

Vibrations of the mounted surface caused by doors opening and closing, audio systems and other installed equipment are automatically corrected to ensure stable shooting.

## ► Night Mode Support

Equipped with Night Mode for infrared shooting. The use of IR rays in low-light situations enables shooting in situations that would normally be difficult, such as when capturing wildlife (image output is black and white).



\* Images are simulated.

## ► Incredible Pan and Tilt Performance

Pan and tilt operate from a minimum speed of 0.08°/s to a maximum of 180°/s in high-speed mode. This is approximately 3 times the speed of our previous model\*<sup>5</sup> for rapid capture of the intended target. Furthermore, a low noise level of NC35 or less has been ensured when operating in normal mode, which is perfect for shooting in quiet environments\*<sup>6</sup>.

### ■ Comparative Pan / Tilt Speeds

Our previous model\*<sup>5</sup>

Maximum speed of 60°/s

AW-UE150W/K

Maximum speed of 180°/s (in high-speed operation mode)

Approx.  
3 times  
the conventional  
speed

## ► Cropping Function

Images shot in 4K can be output in their entirety while simultaneously cropping parts of those images. The cropping position can be specified from a maximum of 3 locations to enable simple operation from the Remote Camera Controller AW-RP150, a web browser or other operations screen.



\* Images are simulated.



Equipped with a large Tally Lamp that is easy to see from a distance

## ► Multiple Interfaces Supported

A wide range of outputs are supported: 12G-SDI, 3G-SDI, HDMI, IP and even Optical Fiber output. The addition of 4K/HD simultaneous output guarantees the right output for the operation at hand. 4K video can be down converted to HD directly within the camera.

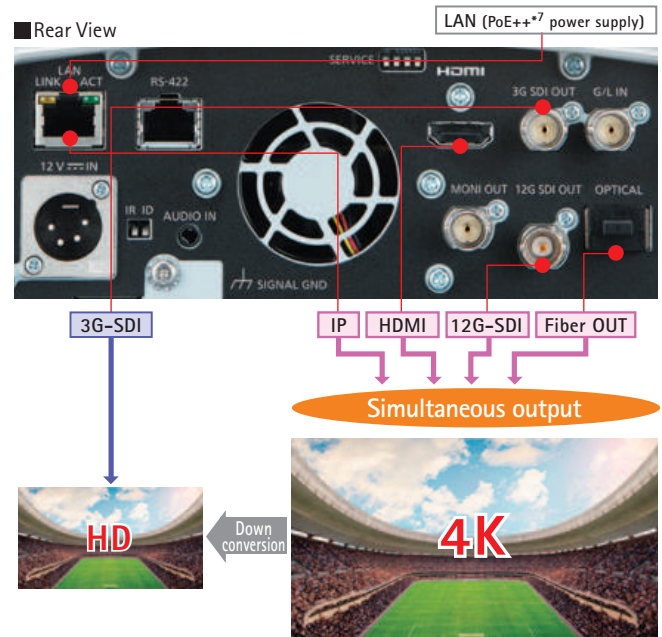

\* Images are simulated.

\*1: Actual output format is UHD (3840 x 2160) 59.94p/50p.

\*2: Native output.

\*3: It denotes "1080/23.98p over 59.94i".

\*4: The display color space does not completely comply with BT.2020. The color balance is shifted to display according to the BT.2020 color gamut.

\*5: Comparison with our previous model, AW-HE130W/K.

\*6: Quietness, stationary accuracy, etc., in high-speed mode may vary from normal mode.

\*7: Abbreviation of Power over Ethernet Plus Plus. Conforms to IEEE802.3bt.

## ▶ Adaptive Matrix prevents color overloaded from blue LEDs\*

Equipped with an Adaptive Matrix function that automatically controls matrix calculation coefficients. This enables shooting while preventing color overloaded, even during live events and on stages with strong blue LED lights.

\*Use may require a software version update.

## ▶ WEB UI Improved

Camera IP image output, settings and control can be performed using a web browser on a computer connected via an IP network. In addition to PCs and Macs, iPads, iPhones\*, Androids and other mobile devices can be used for operation, and this pursuit of easy-to-use interfaces has enabled smooth camera control from remote locations.

\*Use may require a software version update.

Camera control screen (Example below is Windows Ver. 2.62 or later.)

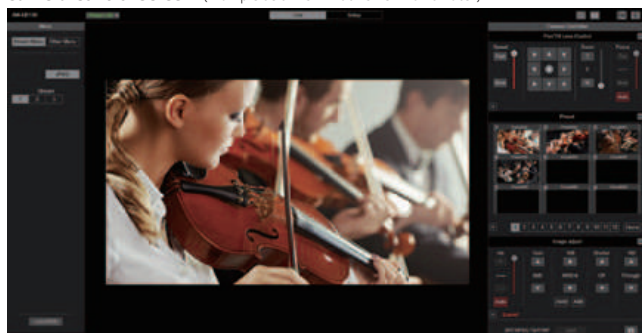

• For supported browsers, see specifications on page 14.

## ▶ AW-RP150 Connection for Large-Scale Production Systems

IP connection from the Remote Camera Controller AW-RP150 through a HUB (switching hub) enables control of up to 200 AW-UE150W/K units. Furthermore, a single AW-UE150W/K unit can be controlled from up to 5 AW-RP150 units.

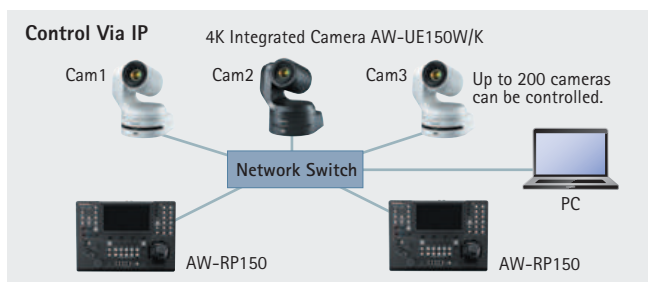

## ▶ Direct Broadcast via RTMP/RTMPS\*

RTMP/RTMPS\* is supported to enable direct upload of video to live-streaming services such as YouTube Live and Facebook Live. This means a live stream can be broadcast directly from the camera.

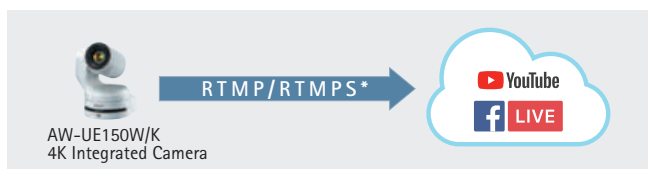

\*RTMP: Real-Time Messaging Protocol. RTMPS: Real-Time Messaging Protocol Secure.

## ▶ NDI® | HX Compatibility for Excellent Video Streaming Quality

The AW-UE150W/K can be upgraded to an NDI® | HX compatible model if purchasing a license. Highly efficient NDI® | HX compatibility enables high-quality video to be encoded and transmitted in real-time and input signals to be directly sent to a switcher (AV-UHS500) without the need for an IP decoder.

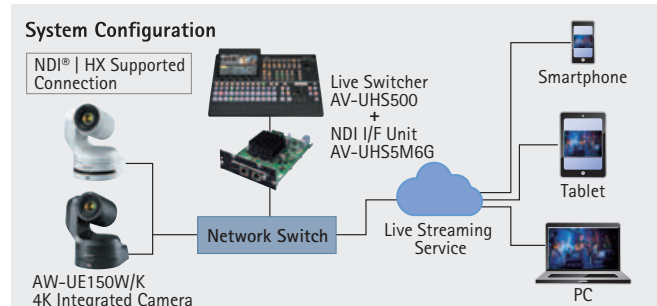

\*4K image output not supported in NDI®|HX mode.

\*Contact your local Panasonic reseller for further information.

• NDI® is a new protocol developed by NewTek, Inc. that supports IP video production workflow. NDI® is a registered trademark of NewTek, Inc. in the United States and other countries. In this instance, NDI®|HX is used to indicate high efficiency low bandwidth NDI®|HX.

## ▶ JPEG Image Saving Function Equipped\*

Up to 100 still images can be captured and saved as JPEG files to the built-in camera memory.

\*Use may require a software version update.

## ▶ Freed\*<sup>1</sup> Support for Construction of AR/VR\*<sup>2</sup> Systems\*<sup>3</sup>

Integration with AR/VR systems is available via Freed-compliant command output. Camera tracking information (pan/tilt/zoom/focus/iris) is output according to a synchronizing signal to facilitate configuration of virtual systems without an encoder.

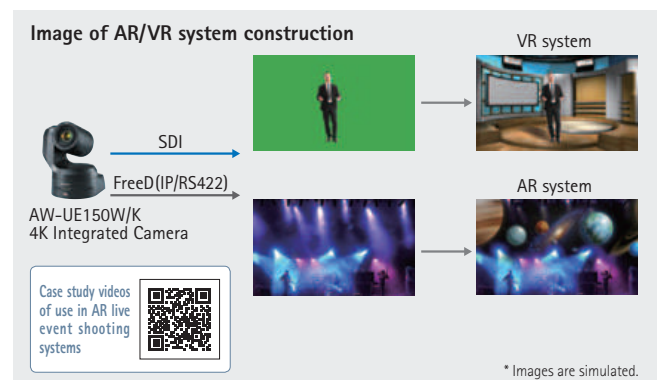

\* Images are simulated.

\*1: A protocol that outputs camera tracking data for AR/VR systems. Camera pan, tilt, zoom and focus information required for uses such as AR/VR composition is output by the AW-UE150W/K.

\*2: AR: Augmented Reality. VR: Virtual Reality.

\*3: Use may require a software version update.

## ▶ V-Log Support\*

Compatible with V-Log, which is equipped on VariCam, our high-end cinema camera. The wide dynamic range and color gamut provide images suited to color grading. Using V-Log-equipped camera recorders and studio cameras enables video production with consistent image creation. Furthermore, two types of settings, V-Log and V-709, can be selected independently per output interface, so that 4K V-Log video for color grading can be output simultaneously with full HD V-709 video for on-site monitoring.

\*Use may require a software version update.

► SRT\*1 support for stable video transmission over public lines\*2

SRT, a next-generation video transmission protocol with strong security suitable for unstable network environments, is supported.

**Secure**

Strong security is ensured by encrypting video data before transmission.

**Reliable**

The packet loss recovery function automatically detects and retransmits packets lost during transmission, ensuring smooth, stable video transmission.

**Transport**

The flexible and adaptable buffer management system enables stable video transmission even in network environments with unstable bit rates. Long-distance video transmission over public lines is supported.

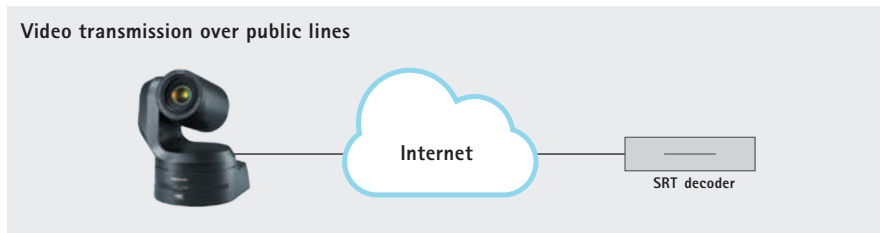
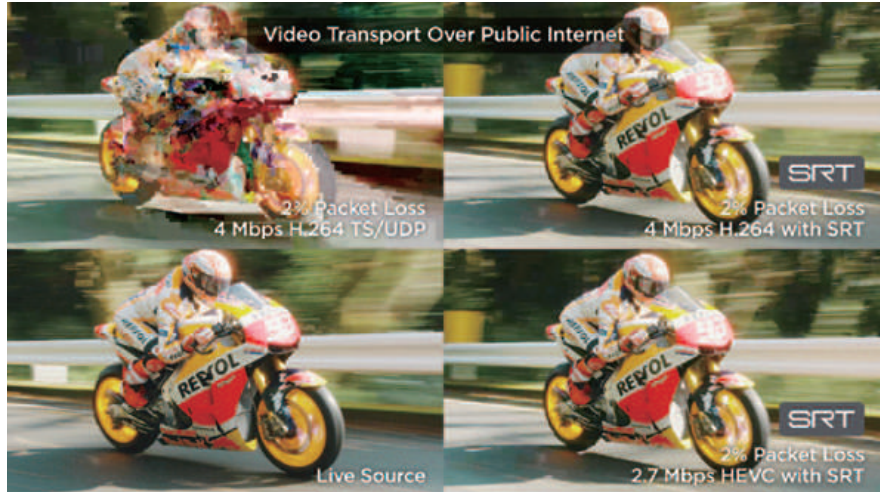

\*1: SRT: Secure Reliable Transport.

\*2: Use may require a software version update.





## ► PC Software for PTZ Camera Support

### Supporting Lecture Capture with Auto Tracking function

#### Auto Tracking Software Key

Stand-Alone and Web App Versions

**AW-SF100**\*1

Server Version

**AW-SF200**\*1

2 Additional Licenses (for AW-SF200)

**AW-SF202**\*1

3 Additional Licenses (for AW-SF200)

**AW-SF203**\*1

- High-performance auto tracking using highly-specialized facial recognition and deep learning technology allows the camera to follow lecturers in any direction, even when they are wearing a mask.
- Operation with IP connection enables installation/control of cameras in remote classroom.
- AW-SF100 allows a single PTZ camera to be controlled on either a stand-alone or web application version. AW-SF200 operates on a server.
- The web application version enables camera control from a tablet, smartphone, desktop PC, etc.
- AW-SF200 enables simultaneous auto tracking and centralized control of multiple cameras.\*2



AW-SF100 / SF200 Main View

90-day Free Trial Available

Free trial

<https://pro-av.panasonic.net/en/software/aw-sf100g/>

\*1: Use may require a software version update.

\*2: Up to four cameras per server can be controlled simultaneously.

\* Depending on the shooting environment, the system may not be able to detect or track the target correctly. Please use this software in an environment where the adjustment work can be performed by the operator to deal with errors in detection and auto tracking. \* There is a 90-day free trial available for the Auto Tracking Software. Please read carefully the precautions for this software and check if it works correctly in your operating environment before you purchase "Auto Tracking Software Activation Key". For further information, please see "Download / Software Download" on the Panasonic website < <https://pro-av.panasonic.net/en/> >.

• The face recognition function is based upon the face recognition software developed by Panasonic Connect Co., Ltd.

### GUI screen that enables the subject of multiple PTZ Cameras to be switched with a single click of an icon

#### Visual Preset Software Key

**AW-SF300**

90-day Free Trial Available

Free trial

<https://pro-av.panasonic.net/en/software/aw-sf300/>

- GUI screens can be set for each shooting location and Preset Groups with registered subject positions can be managed.
- All cameras registered in a group can be directed toward the subject with a single press of the Preset Group icon on the GUI screen.
- Camera positions are displayed as icons on the GUI screen. The icons of cameras in the currently selected Preset Group are highlighted, enabling the user to see which cameras are shooting at a glance.
- Operation using a PC mouse and GUI screen provides ease of use for users who are unfamiliar with the operation of video equipment.

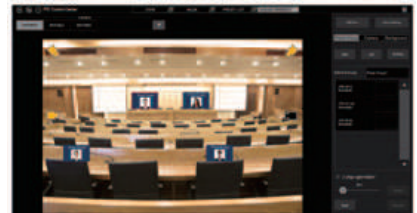

AW-SF300 Main View

\* EasyIP Setup Tool Plus is included with this product and does not need to be installed separately. \* PTZ Control Center must be downloaded before using this product.

### Control multiple PTZ Cameras from PC

#### PTZ Control Center

Free software

- Video can be checked during centralized management of multiple cameras.
- Camera control enabled via GUI for image quality adjustment, pan, tilt, zoom, etc. Touch panel operations are supported.
- Clicking the preset button attached to thumbnails enables simple recall of presets.
- Pan, tilt, zoom and other operations can also be controlled using game controllers made by other companies.



Main screen

### Software that converts PTZ camera on your network into Super Web cam

#### PTZ Virtual USB Driver

Free software

- PTZ cameras on the network can be used as USB cameras for simple execution of web meetings with high image quality.
- Camera controls such as image quality adjustment and pan/tilt/zoom can be operated from the GUI.
- Up to five cameras can be registered.
- Automatic detection of connected cameras and network settings enabled.
- Linking with the video recording and distribution service Panopto enables camera operation through the Panopto GUI.

\* For further information on Panopto, please visit Panopto Website < <https://www.panopto.com> >.

### Freeware to support efficient setup and operation of PTZ Cameras

#### EasyIP Setup Tool Plus

Free software

- Panasonic PTZ Cameras connected to a PC are detected and centralized display and management of camera information such as IP addresses and version numbers can be performed.
- The network setting information of specific PTZ Cameras can be modified from the GUI screen.
- PTZ Cameras can be selected and controlled from a browser GUI.
- Auto IP: Multiple PTZ Cameras can be selected and assigned consecutive IP addresses.
- Firmware Update: PTZ Camera firmware updates can be performed automatically through the tool.\*1

\*1: PC must be connected to the internet. \* This product is included with the AW-SF300 Visual Preset Software Key and PTZ Control Center and does not need to be installed separately.

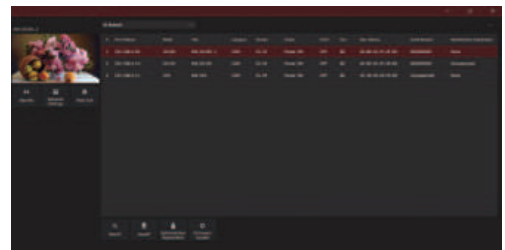

Connected camera information can be checked at a glance on the main screen

\* For further information, please see < [https://pro-av.panasonic.net/en/products/ptz\\_camera\\_systems.html](https://pro-av.panasonic.net/en/products/ptz_camera_systems.html) >.

## ► Optional Products

### ■ Optional Products

As of April, 2022

#### Live Switcher AV-UHS500



#### 8K ROI Camera System (Order-made product)

##### AK-SHB800GJ

(8K Multi Purpose Camera LC Connector Model)

##### AK-SHB800PSJ

(8K Multi Purpose Camera ST Connector Model)

##### AK-SFC101

(Software Key (for Framing Control Software))

##### AK-SHU800EJ

(Image Processing Unit LC Connector Model)

##### AK-SHU800PSJ

(Image Processing Unit ST Connector Model)



#### IT/IP Platform KAIROS



**KAIROS**  
Incredible Productivity



Kairos Core 100



Kairos Control



Kairos Creator

- Use of some optional products may require a main unit software version update.

### ■ Accessories

As of April, 2022



#### Remote Camera Controller AW-RP150

- A separate AC adaptor or PoE+ HUB is required for power supply.



#### Remote Camera Controller AW-RP60

- A separate AC adaptor or PoE HUB is required for power supply.



#### Infrared Wireless Remote Control AW-RM50AG

#### Remote Operation Panel (ROP)

##### AK-HRP1010GJ AK-HRP1015GJ AK-HRP1005\* AK-HRP250GJ

\*Discontinued Products.



AK-HRP1010GJ



AK-HRP1015GJ



AK-HRP1005



AK-HRP250GJ



#### 420 mm (16.5 inches) LCD Video Monitor BT-LH1770P (US Only Model)

- For information on all supported Remote Operation Panels, see the Panasonic website ([https://pro-av.panasonic.net/en/products/compatibility\\_chart/](https://pro-av.panasonic.net/en/products/compatibility_chart/)).
- Use of some accessories may require a main unit software version update.

#### <About power supply>

An AC adaptor is not included with the AW-UE150W/K.  
An XLR4 pin 12 V capacity power supply is required to supply the rated power consumption (48 W) of this device.

## Intuitive Camera Control for Ease of Use and One-Person Operation



A ZOOM/FOCUS rocker mounted on the joystick manages pan and tilt operations for zoom and focus control and intuitive single-handed operation. The built-in touch display allows for easy and quick operation of all essential camera functions.

### AW-RP150

Remote Camera Controller

• Power supply not included. An AC adaptor or PoE+ HUB is required.

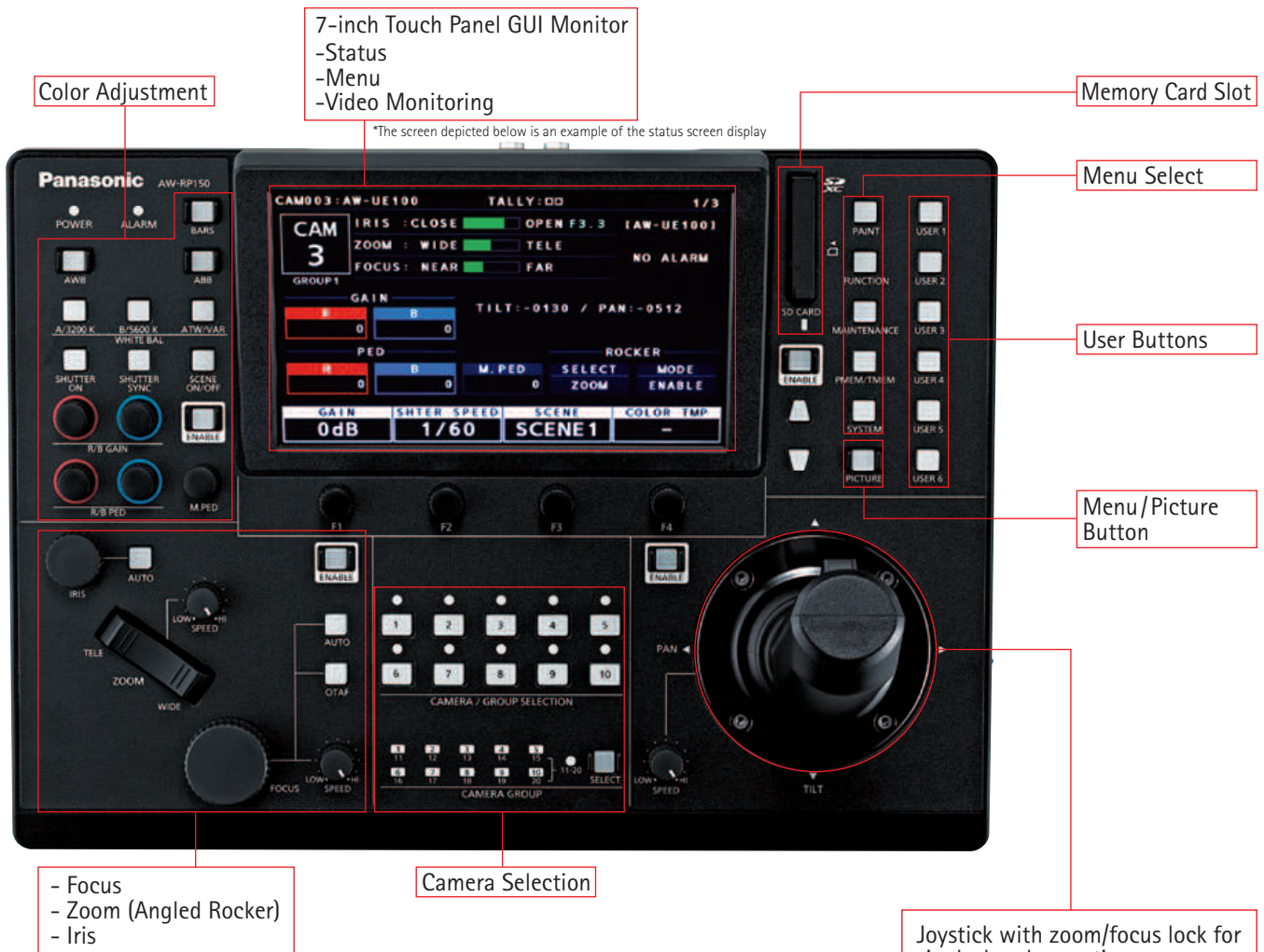

### ► Rear View

PoE+\* support enables power supply via a LAN cable. Additionally, a dual system GPIO (general purpose input/output) terminal is equipped as standard.

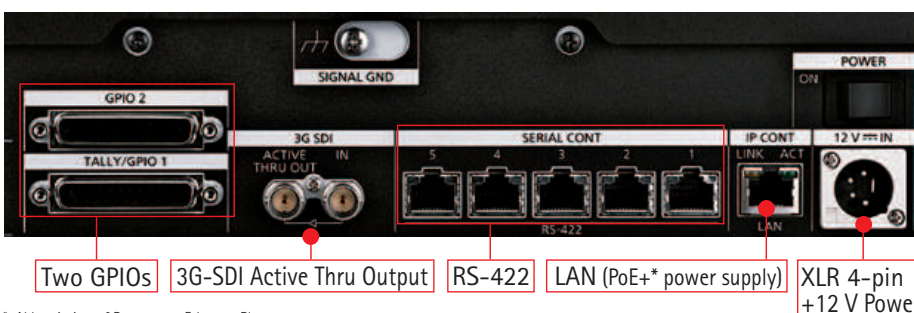

\*: Abbreviation of Power over Ethernet Plus.



**<About power supply>**  
An AC adaptor is not included with the AW-RP150. An XLR4 pin 12 V capacity power supply is required to supply the rated power consumption (12 W) of this device.



## ► Touch Panel GUI for High-Quality Operability and Visibility

The touch panel GUI monitor supports camera image display during shooting as well as a variety of operations. The panel is equipped only with buttons that are frequently used, with menu and camera switching operations, indicators and other functions consolidated in the touch panel GUI.

■ Menu screen example

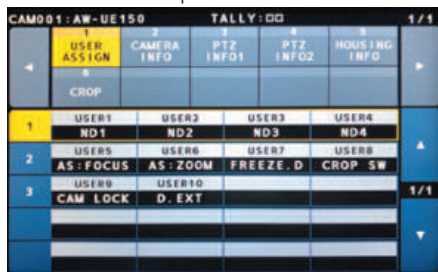

## ► Touch Focus Function Equipped

The focus is quickly aligned to the area touched by tapping the screen. In addition, the Focus in Red display assists with aligning focus by framing the part that is in-focus in red.

■ Focus assist (Focus in Red) screen example



## ► Camera Settings Copied to Multiple Cameras

Scene files, system settings files and other camera settings can be saved on the AW-RP150 SD card. These settings can then be copied to multiple cameras via the SD card. This massively reduces on-location setup time when shooting at events with large numbers of cameras.

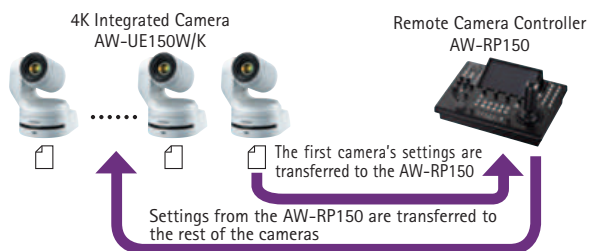

## ► Robotics System Link Support

Robotics systems can be controlled using joystick ZOOM/ FOCUS levers. A PTZ camera and its connected robotics system can be controlled simultaneously, enabling shooting from more flexible angles. Robotics system presets can also be recalled from the unit, improving operation efficiency by consolidating control.

### ROBOTICS Website

- For USA <https://na.panasonic.com/us/making-major-air-moves-with-tecnopoint>
- For Europe <https://business.panasonic.co.uk/professional-camera/robotics-products>

\*Contact a distributor in your region for details on robotics systems for which linking is supported.

## ► Smooth Creation of Cropped Images

The cropping function loaded on the AW-UE150W/K can be controlled from the AW-RP150. Images output from the AW-UE150W/K to the monitor can be cropped in three different locations displayed with colored frames (yellow/green/magenta), and fine-tuned with the joystick as you watch. Required images can be cropped precisely and simply.

■ Cropping screen example



\*This screen is a monitor output image.

\*The image is a composite.

## ► Preset Memory for Simple Camera Control

Registration of the camera angle and other PTZ camera settings allows them to be easily recalled from the touch panel GUI monitor. The movement speed for play back the preset memory can be set by the specified speed or time.

<Supported Presets>

- Pan and tilt position
- Focus position
- White balance settings
- Crop position coordinates
- Zoom position
- Lens aperture (manual iris only)
- Gain

## ► Tracing Memory for Memory and Recall of Camera Operations

The tracing memory function records a series of operation performed for the PTZ camera. Up to 5 minutes for 10 operations can be memorized for a single camera, and that trajectory can then be reproduced.

<Supported Presets>

- Pan and tilt position
- Focus position
- White balance settings
- Zoom position
- Lens aperture (manual iris only)
- Gain

## ► Multiple-Camera Connection Supported for Large-Scale Systems

IP connection via a switching hub can be used to control up to 200 PTZ cameras. Up to 5 PTZ cameras can be controlled in a serial connection.



\*For cameras compatible with AW-RP150, see page 10.

**For indoor use** 

**4K 60p/50p\*1 output, 75.1° horizontal wide-angle output shooting**  
4K Integrated Camera  
**AW-UE150W/K**



● A separate AC adaptor or PoE++ HUB is required for power supply.

**For indoor use** 

**High-end HD model capable of low-noise, high-sensitivity shooting even in dark settings**  
HD Integrated Camera  
**AW-HE145W/K**  
(EU and US Only model)



**For indoor use** 

**Support for a range of video protocols, including Freed\*2 and NDI\*3**  
4K Integrated Camera  
**AW-UE100W/K**



**For indoor use** 

**Top-of-the-line standard model with functions comparable to high-end models**  
4K Integrated Camera  
**AW-UE80W/K NEW**



**For indoor use** 

**Model with SDI output support, suitable for online classes and briefing sessions**  
4K Integrated Camera  
**AW-UE50W/K NEW**

**Standard model suitable for online classes and briefing sessions**  
4K Integrated Camera  
**AW-UE40W/K NEW**



**For indoor use** 

**Compact 4K entry model suitable for use in meeting rooms and classrooms with limited space**  
4K Integrated Camera  
**AW-UE20W/K NEW**



**For indoor use**

**Compact PTZ Camera suitable for use in meeting rooms and classrooms with limited space**  
HD Integrated Camera  
**AW-HE20W/K NEW**



**For indoor use** 

**111° horizontal wide-angle shooting**  
4K Integrated Camera  
**AW-UE4WG/KG**



**For outdoor use**

**High sensitivity, S/N ratio and resolution with IP65 waterproofing and dustproofing**  
Full-HD Outdoor Integrated Camera  
**AW-HR140\*4**



\* For the latest information on PTZ camera compatibility, please see the Panasonic website ([https://pro-av.panasonic.net/en/products/compatibility\\_chart/](https://pro-av.panasonic.net/en/products/compatibility_chart/)).  
\*1: Actual output format is UHD (3840 x 2160) 59.94p/50p. \*2: A protocol that outputs camera tracking data for AR/VR systems. Camera pan, tilt, zoom and focus information required for uses such as AR/VR composition is output by the AW-UE150W/K. \*3: NDI® is a new protocol developed by NewTek, Inc. that supports IP video production workflow. NDI® is a registered trademark of NewTek, Inc. in the United States and other countries. In this instance, NDI® is used to indicate low latency with high bandwidth NDI®. \*4: Use may require a software version update.

Software

Secure remote production over public lines

PTZ Control Center Free software

By linking PTZ Control Center with the AW-RP150, remote production can be performed securely in environments where strict security on internal company networks makes remote shooting more challenging. A PC in a remote location that has PTZ Control Center installed can be connected over public lines to an AW-RP150 on an internal company network that has a serial connection to the PTZ cameras. This creates a system whereby the internal company network does not have an external connection. Camera controls such as pan, tilt and zoom and preset management can be performed through the PTZ Control Center GUI.

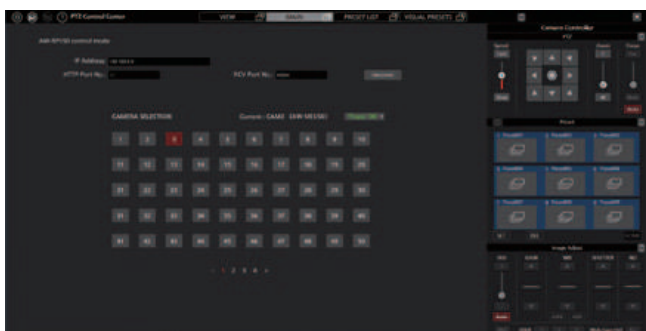

AW-RP150: Operation Mode Screen

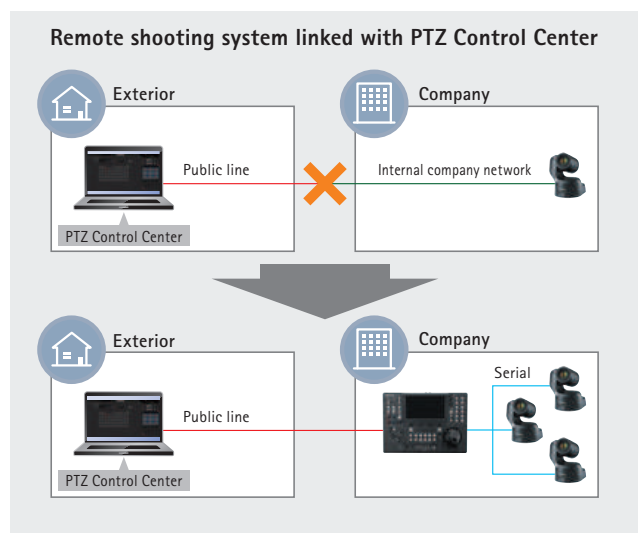



**AW-UE150W/K Dimensions**

Unit: mm (inches)

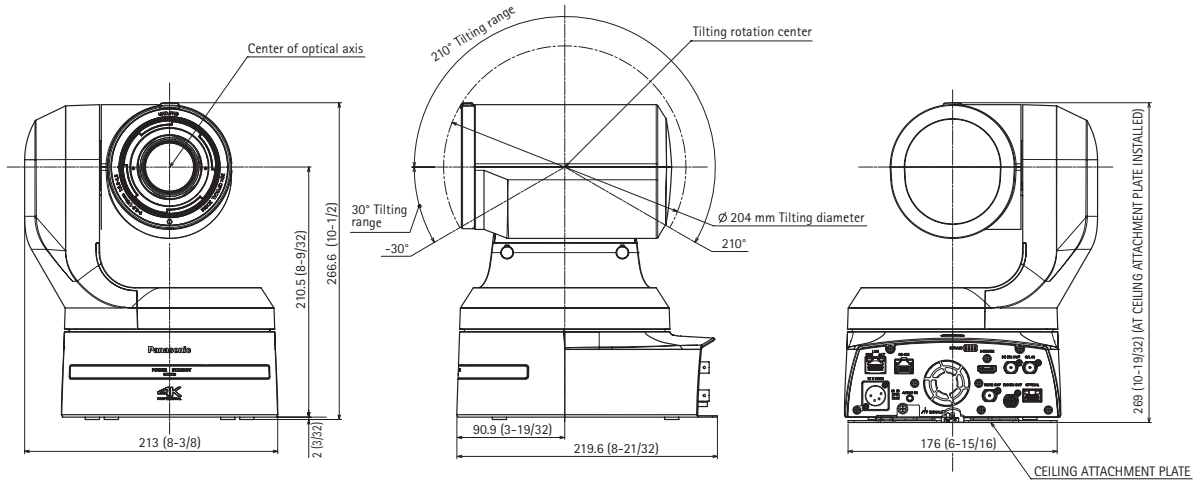

**AW-UE150W/K Bottom View**

Unit: mm (inches)

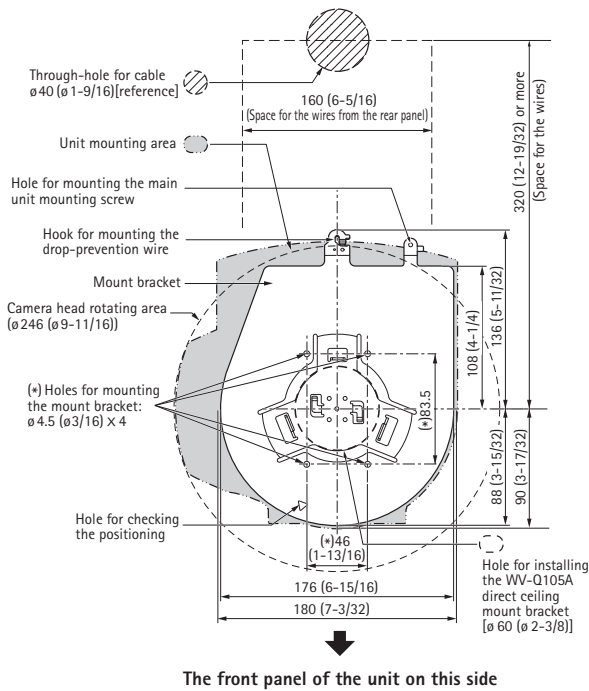

**AW-RP150 Dimensions**

Unit: mm (inches)

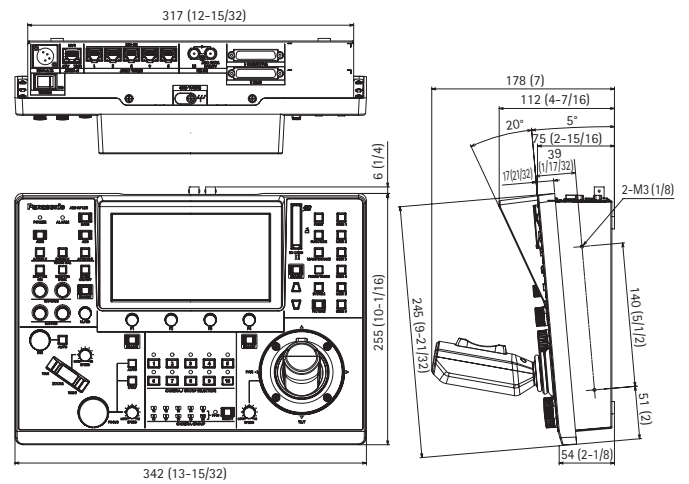

■ Compatible Third-Party Equipment

As of April, 2022

<II-VI Incorporated (Finisar)>

16G Fibre Channel (16GFC)  
10km SFP+ Optical Transceiver  
**FTLF1429P3BNV**  
Operation-verified in Oct. 2018



<GeoVision Inc.>

Gigabit BT PoE++ Adapter  
**GV-PA902BT**  
Operation-verified in Aug. 2020



<NETGEAR, Inc.>

8x1G Ultra90 PoE++ 802.3bt 720W  
2x1G and 2xSFP+ Managed Switch  
**M4250-10G2XF-PoE**  
Operation-verified in Mar. 2021



<Haivision>

Makito X4 Video Decoder  
**Makito X4 Video Decoder**  
Operation-verified in Jul. 2021



See the Panasonic website for information on compatible third-party equipment. <https://pro-av.panasonic.net/en/>

Third-Party Inquiries

- <II-VI Incorporated (Finisar)> <https://ii-vi.com/contact-us/>
- <GeoVision Inc.> TEL: +886-2-8797-8376 MAIL: [sales@geovision.com.tw](mailto:sales@geovision.com.tw)
- <NETGEAR, Inc.> <http://www.netgear.com/home/contact-us/>
- <Haivision> <https://www.haivision.com/contact/>

## Application Examples

See the website for other application examples.

[https://pro-av.panasonic.net/en/solutions/?cid=f\\_r\\_prd\\_mebd-ue150-sol\\_220415](https://pro-av.panasonic.net/en/solutions/?cid=f_r_prd_mebd-ue150-sol_220415)



### Application 01: 4K Studio

#### Studio shooting of smooth, high-quality 4K 60p/50p\*1 images

The AW-UE150W/K is capable of 4K 60p/50p\*1 output for high-quality remote shooting in studio operations where high image quality is required. A large tally lamp has been equipped to make on-air cameras easily identifiable, even from far away.

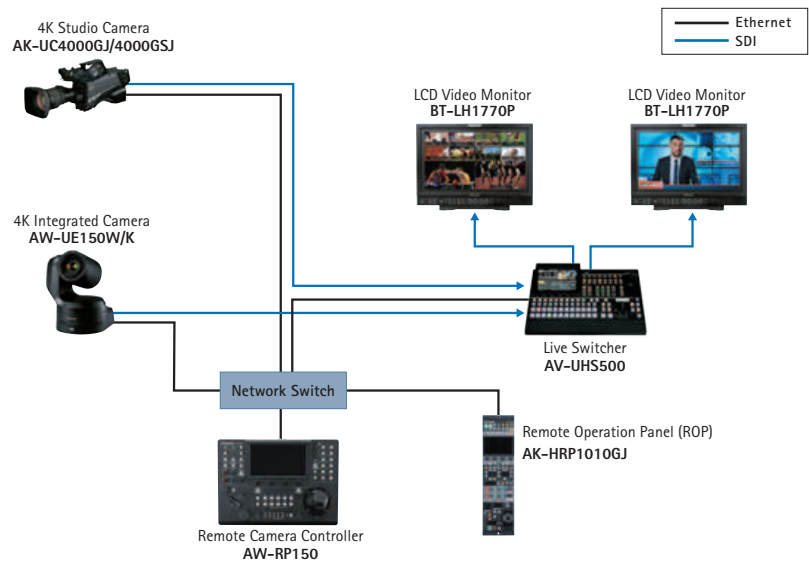

### Application 02: Live Streaming

#### RTMP/RTMPS and NDI® | HX support\*2 enable streaming workflow to be optimized to the situation

Video being shot from a single camera can be uploaded directly from the AW-UE150W/K to a live-streaming service via RTMP/RTMPS. For multi-camera setups, use NDI®|HX\*2 to connect to the Live Switcher AV-UHS500. Multiple AW-UE150W/K units can be controlled from the AV-UHS500 for smooth live streaming.

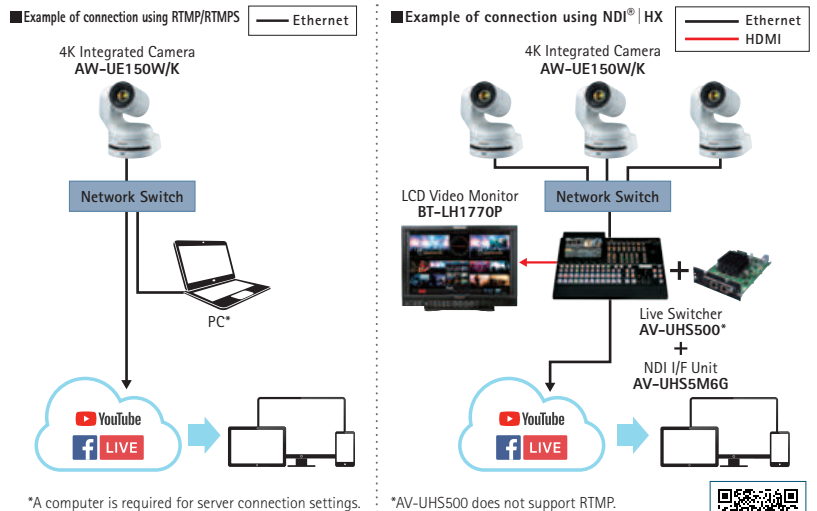

AV-UHS500 website

[https://pro-av.panasonic.net/en/products/av-uhs500/?cid=f\\_r\\_prd\\_mebd-ue150-uhs500\\_220415](https://pro-av.panasonic.net/en/products/av-uhs500/?cid=f_r_prd_mebd-ue150-uhs500_220415)



### Application 03: Halls

#### High-magnification zoom and wide-angle shooting ensure targets are captured clearly in large venues

The large 1.0-type MOS sensor enables high-sensitivity shooting with little noise in halls and other dark locations. The optical 20x zoom further ensures that even far-away targets shot in large venues are captured clearly. 75.1° horizontal wide-angle shooting allows incredible flexibility in shooting location while still being able to capture the entire shot.

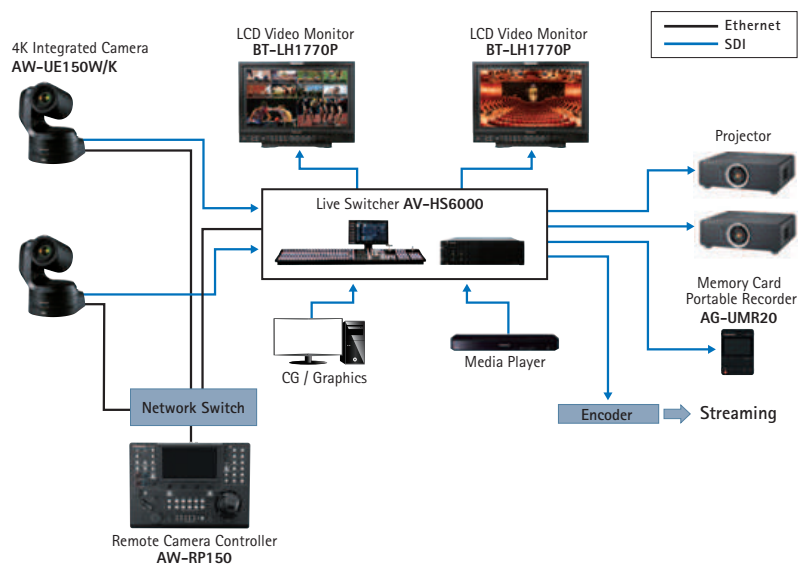



## Application 04 : XR Live Events

### Compact XR<sup>\*3</sup> systems using FreeD<sup>\*4</sup> create video performances with greater freedom

The AW-UE150W/K supports FreeD<sup>\*4</sup>, a protocol for sending information such as pan, tilt and lens positions directly from cameras to 3D rendering engines. By linking with a 3D rendering engine, video from cameras and 3D graphics can be composited in real time. This enables the creation of live XR<sup>\*3</sup> productions with compact systems.

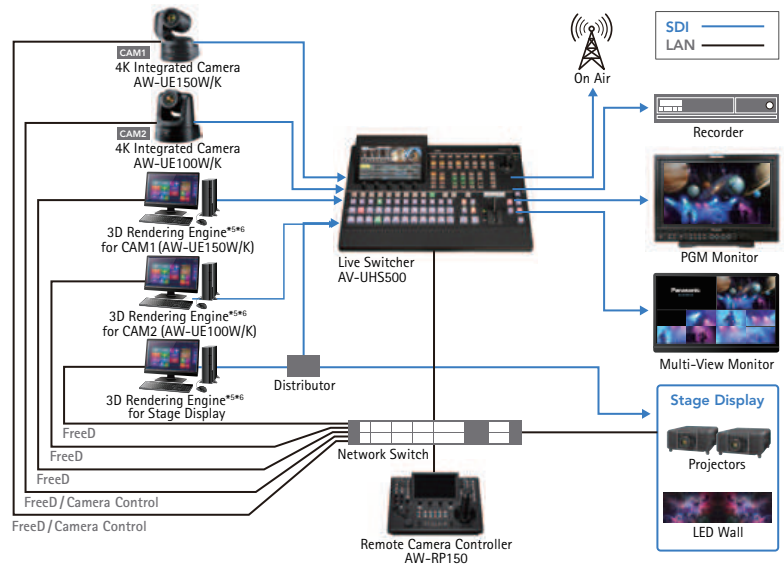

## Application 05 : Sportscasting

### Smooth multi-angle shooting through linking with 8K ROI cameras

Images shot by the AW-UE150W/K can be linked with up to four HD images cropped from the 8K image of an 8K ROI camera. Multiple camera images can be controlled simultaneously, improving operational efficiency in multi-camera/multi-angle recording or broadcasting.

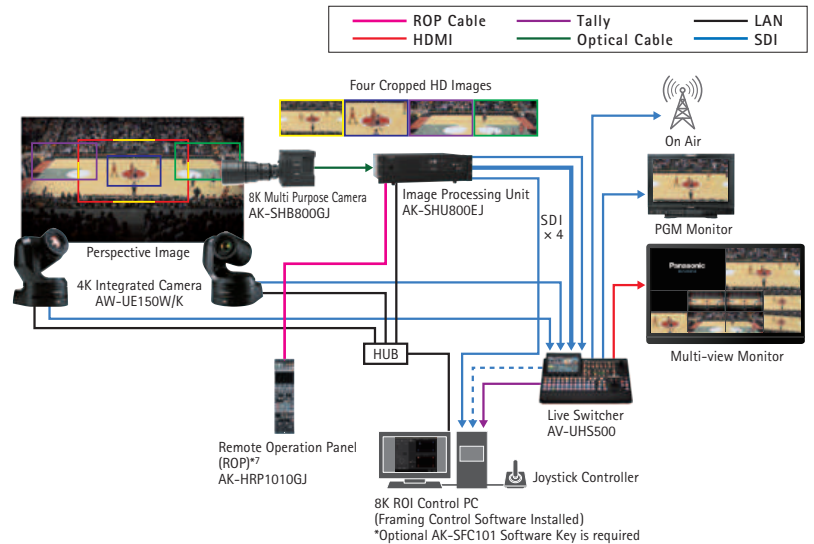

## Application 06 : e-Sports Games

### Compact PTZ cameras for capturing incredible moments

PTZ cameras enable shooting of immersive scenes while keeping players and spectators at the heart of the action. When used in combination with KAIROS, an IT/IP platform that enables simultaneous input of up to 32 HD video elements and angle free multi-screen output, this expands possibilities for a range of video content.

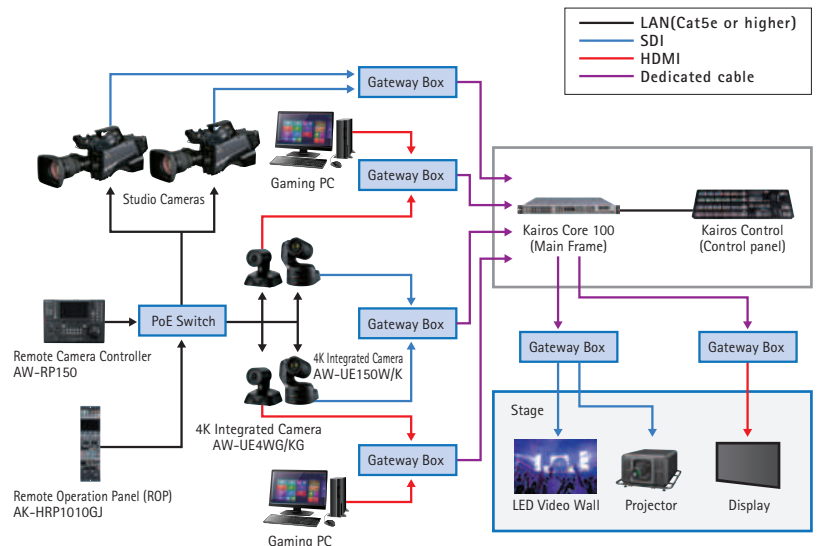
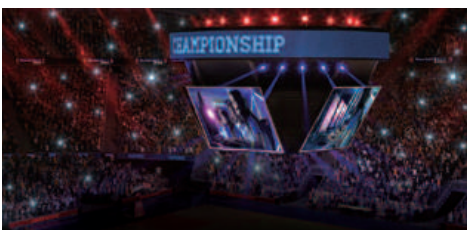

\*1: Actual output format is UHD (3840 x 2160) 59.94p/50p. \*2: Contact your Panasonic sales representative for further details. \*3: X Reality (XR) refers to technologies that merge the real and virtual world to create new experiences. These technologies include augmented reality (AR), virtual reality (VR), mixed reality (MR) and substitutional reality (SR). \*4: A protocol that outputs camera tracking data for AR/VR systems. Camera pan, tilt, zoom and focus information required for uses such as AR/VR composition is output by the AW-UE150W/K. \*5: Video from PTZ cameras and graphics from 3D rendering engines are composited in a Live Switcher AV-UHS500. \*6: 3D rendering engines are systems for generating 3D graphics in real time. \*7: Software must be updated when used with the AK-SHB800 8K Multi Purpose Camera. Once it is updated, it cannot be used except with the 8K Multi Purpose Camera.

## ► Specifications

### AW-UE150W/K

#### <GENERAL>

Power Requirements:	12 V DC (10.8 V to 13.2 V)
PoE++:	IEEE802.3bt standard: DC 42 V to 57 V
Current Consumption:	4.0 A (XLR IN connector), 1.2 A (PoE++ power supply)
Ambient Operating Temperature:	0 °C to 40 °C (32 °F to 104 °F)
Ambient Operating Humidity:	20 % to 90 % (no condensation)
Storage Temperature:	-20 °C to 50 °C (-4 °F to 122 °F)
Mass:	Approx. 4.2 kg (9.24 lb) (excluding mount bracket)
Dimensions (W x H x D):	213 mm x 267 mm x 219 mm (8-3/8 inches x 10-1/2 inches x 8-5/8 inches) (excluding protrusions, direct ceiling mount bracket)
Finish:	AW-UE150WP/AW-UE150WE: Pearl white AW-UE150KP/AW-UE150KE: Black
Controller Supported:	AW-RP150, AW-RP60, AK-HRP1010GJ, AK-HRP1015GJ AK-HRP250GJ

#### <Camera Unit>

Imaging Sensors:	1-type 4K MOS×1										
Effective Pixels:	Approx. 20.18 megapixels										
Lens:	Motorized Optical 20x zoom, F2.8 to F4.5 [f=8.8 mm (11/32 inches) to 176.0 mm (6-15/16 inches); 35 mm (1-3/8 inches) equivalent: 24.5 mm (31/32 inches) to 490.0 mm (19-9/32 inches)]										
Zoom:	<ul style="list-style-type: none"> <li>Optical zoom: 20x</li> <li>i.Zoom: UHD 24x, FHD 32x</li> <li>Digital zoom: 10x</li> </ul>										
Conversion Lens:	Not supported										
Angle of View Range:	Horizontal angle of view: 75.1° (wide) to 4.0° (tele) Vertical angle of view: 46.7° (wide) to 2.3° (tele) Diagonal angle of view: 82.8° (wide) to 4.6° (tele)										
Optical Filter:	Through, 1/4, 1/16, 1/64, IR through (IR through is used as "Night mode")										
Focus:	Switching between auto and manual										
Focus Distance:	Entire zooming range: 1000 mm (3.3 ft) Wide end: 100 mm (0.33 ft)										
Color Separation Optical System:	1MOS										
Standard Sensitivity:	F9, 2000 lx (When normal mode is selected)										
Minimum Illumination:	2 lx (F2.8, 59.94p, 50IRE, 42 dB, without accumulation)										
S/N:	60 dB or more										
Horizontal Resolution:	2,000 TV lines Typ (Center area)										
Gain Selection:	Auto, -3 dB to 36 dB* Super Gain function equipped : 37 dB to 42 dB										
Frame Mix**:	0 dB, 6 dB, 12 dB, 18 dB, 24 dB										
Electronic Shutter Speed:	<table border="1"> <tr> <td>59.94p/59.94i</td> <td>1/60, 1/100, 1/120, 1/250, 1/500, 1/1000, 1/2000, 1/4000, 1/8000, 1/10000</td> </tr> <tr> <td>29.97p</td> <td>1/30, 1/60, 1/100, 1/120, 1/250, 1/500, 1/1000, 1/2000, 1/4000, 1/8000, 1/10000</td> </tr> <tr> <td>23.98p/24p</td> <td>1/24, 1/48, 1/60, 1/100, 1/120, 1/250, 1/500, 1/1000, 1/2000, 1/4000, 1/8000, 1/10000</td> </tr> <tr> <td>50p/50i</td> <td>1/60, 1/100, 1/120, 1/250, 1/500, 1/1000, 1/2000, 1/4000, 1/8000, 1/10000</td> </tr> <tr> <td>25p</td> <td>1/25, 1/50, 1/60, 1/100, 1/120, 1/250, 1/500, 1/1000, 1/2000, 1/4000, 1/8000, 1/10000</td> </tr> </table>	59.94p/59.94i	1/60, 1/100, 1/120, 1/250, 1/500, 1/1000, 1/2000, 1/4000, 1/8000, 1/10000	29.97p	1/30, 1/60, 1/100, 1/120, 1/250, 1/500, 1/1000, 1/2000, 1/4000, 1/8000, 1/10000	23.98p/24p	1/24, 1/48, 1/60, 1/100, 1/120, 1/250, 1/500, 1/1000, 1/2000, 1/4000, 1/8000, 1/10000	50p/50i	1/60, 1/100, 1/120, 1/250, 1/500, 1/1000, 1/2000, 1/4000, 1/8000, 1/10000	25p	1/25, 1/50, 1/60, 1/100, 1/120, 1/250, 1/500, 1/1000, 1/2000, 1/4000, 1/8000, 1/10000
59.94p/59.94i	1/60, 1/100, 1/120, 1/250, 1/500, 1/1000, 1/2000, 1/4000, 1/8000, 1/10000										
29.97p	1/30, 1/60, 1/100, 1/120, 1/250, 1/500, 1/1000, 1/2000, 1/4000, 1/8000, 1/10000										
23.98p/24p	1/24, 1/48, 1/60, 1/100, 1/120, 1/250, 1/500, 1/1000, 1/2000, 1/4000, 1/8000, 1/10000										
50p/50i	1/60, 1/100, 1/120, 1/250, 1/500, 1/1000, 1/2000, 1/4000, 1/8000, 1/10000										
25p	1/25, 1/50, 1/60, 1/100, 1/120, 1/250, 1/500, 1/1000, 1/2000, 1/4000, 1/8000, 1/10000										
Synchro Scan:	<table border="1"> <tr> <td>59.94p/59.94i</td> <td>60.00 Hz to 7200 Hz</td> </tr> <tr> <td>29.97p</td> <td>30.00 Hz to 7200 Hz</td> </tr> <tr> <td>23.98p/24p</td> <td>24.00 Hz to 7200 Hz</td> </tr> <tr> <td>50p/50i</td> <td>50.00 Hz to 7200 Hz</td> </tr> <tr> <td>25p</td> <td>25.00 Hz to 7200 Hz</td> </tr> </table>	59.94p/59.94i	60.00 Hz to 7200 Hz	29.97p	30.00 Hz to 7200 Hz	23.98p/24p	24.00 Hz to 7200 Hz	50p/50i	50.00 Hz to 7200 Hz	25p	25.00 Hz to 7200 Hz
59.94p/59.94i	60.00 Hz to 7200 Hz										
29.97p	30.00 Hz to 7200 Hz										
23.98p/24p	24.00 Hz to 7200 Hz										
50p/50i	50.00 Hz to 7200 Hz										
25p	25.00 Hz to 7200 Hz										
Gamma:	HD / FILMLIKE1 / FILMLIKE2 / FILMLIKE3 / FILM REC / VIDEO REC / HLG										
White Balance:	ATW : 3200K, 5600K ATW Speed : Normal / Slow / Fast AWB : AWB-A / AWB-B VAR (selectable between 2000K and 15000K by designating a value)										
Chroma Amount Variability:	OFF, -99 % to 99 %										
Scene File:	Scene1, Scene2, Scene3, Scene4										
Output Format:	<table border="1"> <tr> <td>4K</td> <td>2160/59.94p, 2160/50p, 2160/29.97p*, 2160/25p*, 2160/24p*, 2160/23.98p*</td> </tr> <tr> <td>HD</td> <td>1080/59.94p, 1080/50p, 1080/29.97p*, 1080/29.97PsF, 1080/25p*, 1080/25PsF, 1080/23.98p*, 1080/24p*, 1080/23.98p*, 1080/23.98PsF, 1080/59.94i, 1080/50i, 720/59.94p, 720/50p</td> </tr> </table>	4K	2160/59.94p, 2160/50p, 2160/29.97p*, 2160/25p*, 2160/24p*, 2160/23.98p*	HD	1080/59.94p, 1080/50p, 1080/29.97p*, 1080/29.97PsF, 1080/25p*, 1080/25PsF, 1080/23.98p*, 1080/24p*, 1080/23.98p*, 1080/23.98PsF, 1080/59.94i, 1080/50i, 720/59.94p, 720/50p						
4K	2160/59.94p, 2160/50p, 2160/29.97p*, 2160/25p*, 2160/24p*, 2160/23.98p*										
HD	1080/59.94p, 1080/50p, 1080/29.97p*, 1080/29.97PsF, 1080/25p*, 1080/25PsF, 1080/23.98p*, 1080/24p*, 1080/23.98p*, 1080/23.98PsF, 1080/59.94i, 1080/50i, 720/59.94p, 720/50p										

#### <Synchronization System>

Internal / External synchronization (BBS / Tri-level sync)

#### <INPUT>

Input Connector:	DC 12 V IN, G/L IN (BNC) • BBS (Black Burst Sync), tri-level sync supported
------------------	--

#### <OUTPUT>

Video Output:	HDMI	HDMI 2.0 standard 4:2:2/10bit • HDCP is not supported. • Viera Link is not supported.
	12G-SDI OUT	SMPTTE2802-1 / SMPTE424M / SMPTE292M standard • Level-A / Level-B supported
	3G-SDI OUT	SMPTTE424M / SMPTE292M / 75 Ω (BNC x 1) • Level-A / Level-B supported
	MONI OUT	SMPTTE292 / 75 Ω (BNC x 1)
	Optical Fiber	SFP+ standard • The signal sent is the same as 12G-SDI OUT. • This unit does not support input by optical signals.

#### <INPUT/OUTPUT>

Input / Output Connector:	LAN	LAN connector for IP control (RJ-45)
	RS-422	CONTROL IN RS-422A (RJ-45)
	MIC/LINE input	<ul style="list-style-type: none"> <li>ø 3.5 mm stereo mini jack</li> <li>Input impedance: High impedance</li> <li>• During MIC input</li> <li>Supported mic: Stereo mic (plug-in power, on/off switching via menu)</li> <li>Supply voltage: 2.5 V ± 0.5 V</li> <li>Mic input sensitivity: Approx. -40 dBV ± 3 dBV (0 dB=1 V/Pa, 1 kHz)</li> <li>• During LINE input</li> <li>Input level: Approx. -10 dBV ± 3 dBV</li> </ul>

#### <Pan-tilt Head Unit>

Camera/Pan-tilt Head Control:	IP connecting cable • LAN cable***: (category 5e or above, straight cable / crossover cable) max. 100 m (328 ft)
	AW protocol connecting cable LAN cable** (category 5e or above, straight cable) max. 1000 m (3280 ft)
Installation Method:	Stand-alone (Desktop) or suspended (Hanging)*
Pan/tilt Operation Speed:	Minimum speed 0.08°/s Maximum speed 60°/s or higher** • Maximum speed is 180°/s in high-speed mode
Panning Range:	±175°
Tilting range:	-30° to 210°**
Quietness:	NC35 or less

#### <Supported operating systems and web browsers\*10>

Supported operating systems and web browsers:	Windows	Microsoft® Windows® 10 Microsoft Edge Google Chrome
	Mac	Mac OS 10.13, Mac OS 10.12, Mac OS 10.11, Safari 11, Google Chrome
	iPhone / iPad	iOS 11.4.1 Google Chrome

#### <IP Streaming>

Image Streaming Mode:	JPEG (MJPEG), H.264, H.265
Image Resolution:	3840×2160, 1920×1080, 1280×720, 640×360, 320×180
Image Transmission setting (JPEG):	Frame Rate: Maximum 30 fps Image quality (Fine / Normal)
Image Transmission Setting (H.264):	<ul style="list-style-type: none"> <li>■ Image quality (Motion priority / Image quality priority) UHD 60 fps / 50 fps</li> <li>■ Transmission Type: Unicast port (AUTO) Unicast port (MANUAL) Multicast port</li> <li>■ Transmission Priority Constant bit rate Frame rate Best effort</li> </ul>



Image Transmission Setting (H.264):	<ul style="list-style-type: none"> <li>■ Frame Rate [60Hz] 5fps/15fps/30fps/60fps (UHD: 30fps, 60fps) [50Hz] 5fps/12.5fps/25fps/50fps (UHD: 25fps, 50fps)</li> <li>■ Max Bit Rate HD : 512kbps/768kbps/1024kbps/1536kbps/2048kbps/3072kbps/4096kbps/6144kbps/8192kbps/10240kbps/12288kbps/14336kbps/16384kbps/20480kbps/24576kbps/32768kbps/40960kbps/51200kbps/76800kbps UHD: 12800kbps/25600kbps/51700kbps/76800kbps</li> </ul>
Image Transmission Setting (H.265):	<ul style="list-style-type: none"> <li>■ Image Transmission Type: Unicast port (AUTO) Unicast port (MANUAL) Multicast port</li> <li>■ Frame Rate [60Hz] 60fps/30fps [50Hz] 50fps/25fps</li> <li>■ Max Bit Rate 1024kbps/1536kbps/2048kbps/3072kbps/4096kbps/6144kbps/8192kbps/10240kbps/12288kbps/14336kbps/16384kbps/20480kbps/24576kbps/</li> </ul>
Audio Compression Type:	AAC-LC, 48 kHz / 16 bit / 2ch

Supported Protocol:	<ul style="list-style-type: none"> <li>■ IPv6 : TCP / IP, UDP / IP, HTTP, HTTPS, DNS, NTP, DHCPv6, RTP, MLD, ICMP, ARP, RTMP, RTMPS, SRT, MPEG2-TS over, UDP, SNMP</li> <li>■ IPv4 : TCP / IP, UDP / IP, HTTP, HTTPS, RTSP, RTP / RTCP, DHCP, DNS, DDNS, NTP, UPnP, IGMP, ICMP, ARP, RTMP, RTMPS, SRT, MPEG2-TS over, UDP, SNMP</li> </ul>
---------------------	--

### <Other Function>

NDI® support\*11: NDI® | HX version 2

Tally LED display color: red / green

\*1: 1 dB step increments can be set. \*2: This cannot be configured when the format is 2160/29.97p, 2160/23.98p, 2160/24p, 2160/25p, 1080/29.97p, 1080/23.98p(59.94i), 1080/29.97PsF, 1080/23.98PsF, 1080/25p, 1080/25PsF. \*3: Native output. \*4: It denotes "1080/23.98p over 59.94i". \*5: Use of an STP (shielded twisted pair) cable is recommended. \*6: Category 6 or more is used when sending 4K images. \*7: To ensure safety, the unit must be secured using the mount bracket supplied. \*8: Quietness, stationary accuracy, etc., in high-speed mode may vary from normal mode. \*9: Depending on the pan or tilt position, the camera may be reflected in the image. \*10: Compatible operating systems and browsers are as of April 2022. For the latest information on OS/browser support, please see the Panasonic website (<https://pro-av.panasonic.net/en/>). \*11: Contact your local Panasonic vendor for further information.

## AW-RP150

### <GENERAL>

Power Requirements:	12 V DC (10.8 V to 13.2 V)
PoE+:	IEEE802.3at standard: DC 42 V to 57 V
Current Consumption:	1.0 A (Connector Input) 0.6 A (PoE+ power supply)
Ambient Operating Temperature:	0 °C to 40 °C (32 °F to 104 °F)
Allowable Humidity:	20% to 90% (no condensation)
Storage Temperature:	-20 °C to 50 °C (-4 °F to 122 °F)
Weight:	Approx. 3.2 kg (7.05 lb)
Dimensions (W x H x D):	342 mm x 178 mm x 255 mm (13-15/32 inches x 7 inches x 10-1/16 inches) (excluding protrusions)
Connection Supported Equipment:	IP/RS422 AW-UE150W/K, AW-HR140*1, AW-HE130W/K*1*2, AW-HN130W/K*1*2, AW-UE100W/K*1, AW-UE80W/K*1, AW-UE70W/K*1*2, AW-UN70W/K*1*2, AW-UE50W/K*1, AW-UE40W/K*1, AW-UE20W/K*1, AW-HE42W/K*1*2, AW-HE40 Series*1*2, AW-HN40HW/HK*1*2, AW-HE38HW/HK*1*2, AW-HN38HW/HK*1*2, AW-HE20W/K*1, AW-UE4WG/KG*1

### <Input/Output Connectors>

Input:	DC 12 V IN XLR 4-pin
	3G-SDI IN SMPTE292 / 75 Ω (BNC x 1) Supported formats: 1080/59.94p*1, 1080/50p*1, 1080/59.94i, 1080/50i, 1080/23.98p, 1080/25p, 1080/23.98PsF, 1080/25PsF
Output:	ACTIVE THRU OUT SMPTE292 / 75 Ω (BNC x 1)
Input/Output:	IP CONT 100BASE-TX PoE+ input Connection cable: LAN cable, max. 100 m (328 ft) • When connecting the unit via a switching hub: Straight cable or a cross cable (category 5 cable), STP (Shielded Twisted Pair) cable recommended • When connecting the unit directly: Crossover cable (category 5 cable), STP (Shielded Twisted Pair) cable recommended
	SERIAL CONT (RJ-45): RS-422 (control signals for PTZ cameras), TALLY OUT Connecting cable: Straight cable (category 5e or better shielded cable), max. 1000 m (3280 ft) TALLY OUT: Open collector output (negative logic) Maximum voltage resistance DC 24 V, Maximum current 50 mA

Input/Output:	TALLY/GPIO 1	D-sub 25-pin, female, inch thread TALLY IN : 10 inputs (for receiving photocoupler signals) GPIO : 6 inputs (for receiving photocoupler signals) GPIO : 5 inputs (for receiving photocoupler signals) or 5 outputs (open collector outputs, negative logic) • Input/output switched with menu settings
	GPIO 2	D-sub 25-pin, female, inch thread GPIO : 10 inputs (for receiving photocoupler signals) GPIO : 10 inputs (for receiving photocoupler signals) or 10 outputs (open collector outputs, negative logic) • Input/output switched with menu settings Reserve connectors: 2 connectors (For future expansion feature)
LCD Display:	7-inch Touch Panel GUI Monitor (WVGA (800x480))	
SD Memory Card Slot :	SDHC / SDXC Memory Card Slot x 1	

### <Connection Specifications >

No. of Connectable Cameras:	200 (IP), 5 (RS422)
No. of Camera Selection Buttons:	10
No. of Camera Groups:	20 (10 units per 1 group)

### <Memory>

Preset Memory:	No. of memory presets	100
Tracing Memory:	No. of cameras	Cam1 to Cam10
	Recording time, no. of memory settings	Maximum 5 min. total per camera, maximum of 10 settings per camera

### <Other Functions>

No. of User Assignable Buttons:	6 + up to 10 on the LCD menu
Pan / Tilt Speed Adjustment:	7 levels
Tally LED Display Color:	green / red

\*1: Use may require a software version update.

\*2: Stock Limited.

\*3: Level-A support only.

- \* Microsoft®, Windows® and Windows® 10 are either registered trademarks or trademarks of Microsoft Corporation in the United States and other countries.
- \* Apple, Mac, OS X, iPhone, iPod Touch, iPad, and Safari are registered trademarks of Apple Inc., in the United States and other countries.
- \* Android™ is a trademark of Google Inc.
- \* "YouTube" and the "YouTube logo" are registered trademarks of Google Inc.
- \* "Facebook" is a registered trademark of Meta Platforms, Inc.
- \* NDI® is a new protocol developed by NewTek, Inc. that supports IP video production workflow. NDI® is a registered trademark of NewTek, Inc. in the United States and other countries. In this instance, NDI® is used to indicate low latency with high bandwidth NDI®, NDI® | HX is used to indicate high efficiency low bandwidth NDI® | HX.

\* Specifications are subject to change without notice.

# Panasonic®

Panasonic Connect Co., Ltd.  
2-15 Matsuba-cho, Kadoma, Osaka 571-8503 Japan



For more information, please visit Panasonic web site  
<https://pro-av.panasonic.net/en/qr/>



Factories of Panasonic Connect Co., Ltd. have received ISO14001:2015-the Environmental Management System certification. (Except for 3rd party's peripherals.)



**Broadcast and Professional AV Website**



**Contact Information**



**Facebook**



**Mobile App**